

VOLVO PENTA IPS 1050 INBOARD PERFORMANCE SYSTEM

588 kW (800 hp) crankshaft power acc. to ISO 8665

A revolutionary propulsion system for high speed work & patrol boats

Buyers and users of fast crew boats, work boats, patrol boats and other vessels with traditional inboard propulsion have an increasing demand for reduced emissions – in particular the NO_x & Co₂ levels – but also for improved handling, enhanced onboard comfort, higher speed, and fuel savings. The Volvo Penta IPS system is the answer, combining all the above with reliability and outstanding environmental properties.



Overview

The successful Volvo Penta IPS propulsion system is being expanded further with a third and most powerful version matched together with our new 13 litre engine. This means we are reinforcing the IPS range to a performance power level equal to 1050 shaft hp, suitable for 25 meters planning work & patrol boats in twin installation. In triple and quad applications the system reaches a power level up to 4200 shaft hp, applicable for vessels in 30 meter range. The new larger Volvo Penta IPS 3 version shares concept, technology and software with the successful IPS 1 and IPS 2 pod systems, thereby setting new standards in:

- Improved efficiency, higher speed with less power, reduced fuel consumption/extended range, and powerful acceleration
- Substantially enhanced maneuverability regardless of speed and excellent course keeping capability offers safe and predictable handling
- Onboard comfort is greatly enhanced thanks to much lower levels of sound, vibrations and exhaust fumes
- Installation is greatly simplified
- More space available for cargo
- Improved safety and redundancy
- Ease of service, the complete system from helm to propeller cone supported by one supplier

All this is combined with the usual benefits of a traditional inboard such as a robust, high strength construction, excellent corrosion resistance and the propellers under the hull.

Efficiency and performance

With outstanding efficiency over the whole speed range, (see the upper curve in the diagram) the Volvo Penta IPS offers :

- Increased speed
- Reduced fuel consumption
- Faster acceleration
- Much lower emissions per nautical mile

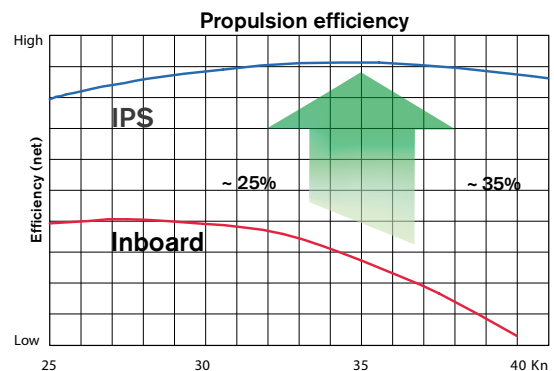

**VOLVO
PENTA**

VOLVO PENTA IPS 1050

As an example, the diagram shows the required power at various speeds for a 18 meter, twin installation, 27 ton mono hull. In general terms, if the top speed is above 35 knots, the performance advantage is as much as 35% (equal to approx. 275 hp/engine), while below 35 knots the difference is approx. 25% (i.e. 200 hp/engine). Due to the much higher efficiency with the Volvo Penta IPS system, the fuel consumption and environmental impact will be reduced correspondingly.

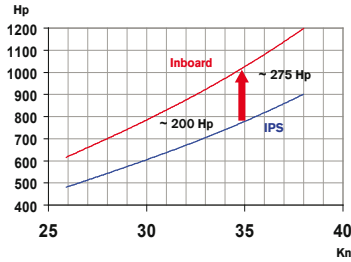

Thanks to this superior efficiency, the product designations 1050 communicate the power required for a conventional shaft installation to reach a comparable performance level.

Why is Volvo Penta IPS so superior?

Part of the improvement in efficiency can be attributed to state of the art Volvo Penta engines - but most of it is achieved thanks to the Volvo Penta IPS propulsion unit. Let's look at what happens beneath the surface:

- Volvo Penta IPS is a complete integrated and optimized propulsion system from helm to propeller cone.
- The twin, counter rotating propellers are forward facing at the front of the hydro dynamically optimized pod unit, working in undisturbed water.
- The pod unit is designed for an efficient flat hull surface with maximum buoyancy. The propeller thrust is parallel with hull. All the power drives the boat forward.
- The propeller position is well under the hull giving minimum risk for cavitation caused by air intrusion and less subject to marine growth.

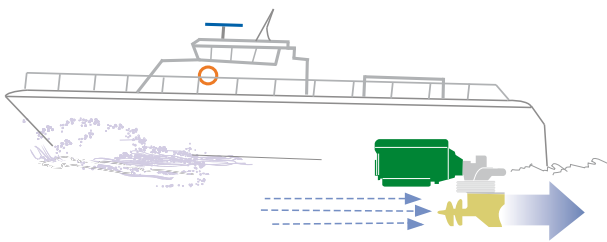

The patented twin counter-rotating seven-blade (3+4) propellers mean:

- less load on each propeller, and no rotational losses
 - minimized tip losses and cavitation
 - no through-hub exhaust optimizes large blade area in relation to hub diameter
 - optimized gear ratio
 - No side forces created
- All the above result in maximum efficiency and smooth running.

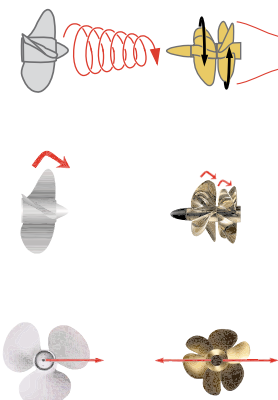

- A conventional shaft system loses efficiency with the thrust angled downward. Shaft and rudder is also causing a significant drag which is increasing with the speed

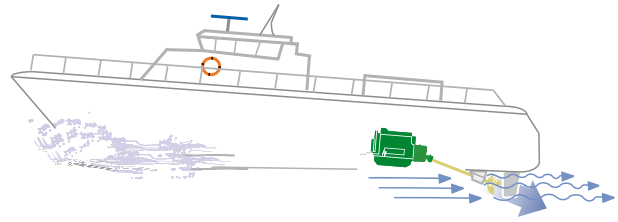

Maneuvering and handling

Maneuvering and handling are areas where Volvo Penta IPS truly sets a completely new standard. Forget everything you know about complicated docking maneuvers. Driving the boat is both safe and economical!

The reason for this excellent maneuverability is:

- The propulsion units are individually steerable turning and pointing the entire thrust in the desired direction. This substantially enhances maneuverability and gives direct response to helmsmans commands.
- Twin counter-rotating propellers on each hydro dynamically optimized pod unit means superior thrust and no side forces, resulting in excellent course keeping capability.
- Electronic controls give a distinct and precise feeling, and shifting is immediate. Thanks to the progressive electronic steering the wheel spins easier at low speed, further reducing driver effort.
- The system can also be equipped with revolutionary features such as Joystick, docking station and Dynamic Positioning System.

Comfort

Onboard comfort is important for professional users working full days at sea. Minimal levels of sound, vibration and exhaust fumes make life aboard that much more pleasant. Volvo Penta have put in a lot of design features to reduce noise & vibrations.

- The propulsion forces and vibrations are absorbed by the combined rubber suspension and sealing. A flexible U-joint drive shaft between engine and drive unit allows the engine to be soft suspended, which efficiently reduces engine vibrations.

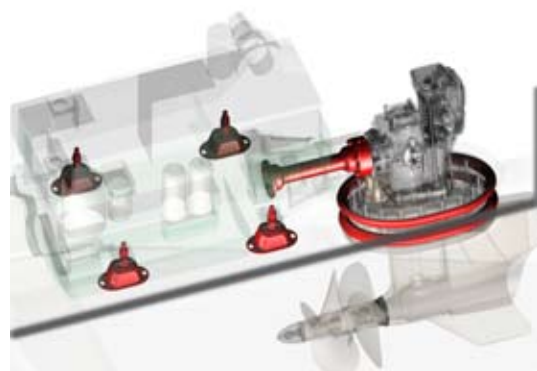

VOLVO PENTA IPS 1050

- The propellers are producing horizontal thrust and are working in undisturbed water with no cavitation.
- Increased number of propeller blades (7) with smaller diameter and reduced blade load, in combination with good tip clearance to the hull, means that the pressure pulses created by the propellers have very little effect on the hull.

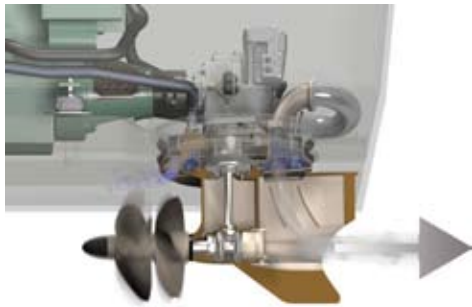

Installation

A complete system in a robust design

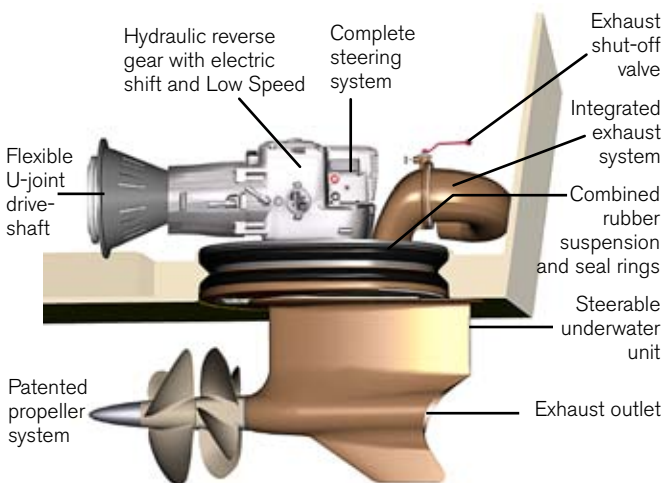

The Volvo Penta IPS has been developed and is manufactured as a complete integrated system from the helm to the propeller cone – engine, propulsion unit incl. gear box, propellers, exhaust and seawater system, steering, instruments and controls. Installing the units is easy. Our own tests show installation time reduced by well over 50%.

The Volvo Penta IPS system can be installed with various lengths of drive shafts for different boat designs.

The system is always installed in a twin or multiple engine configuration.

A special mounting collar is integrated in the hull construction. The propulsion pod is conveniently lifted in place from beneath the hull, with the combined rubber suspension and sealing already in place. The clamp ring is easily positioned and quickly attached with standard bolts. No time-consuming alignment is needed. Steering, shift and throttle plus instrumentation are simply installed with plug-in connectors.

Safety and quality

The Volvo Penta IPS system is designed with safety as a key feature: robust design, flexible suspension and redundancy in the EVC system.

Everything in contact with seawater is either made from a specially formulated nickel-aluminum-bronze alloy or stainless steel. Propulsion unit, bearings, couplings, sealings etc. are all robustly dimensioned to cope with the unexpected and ensure a really long and trouble-free service life. A large anode is also linked to the system as standard. The Volvo Penta ACP Anti Corrosion Protection system can be added as option.

Volvo Penta EVC, Electronic Vessel Control, links the system components together, handling all user interface and monitoring including shift, throttle and steering. This CAN-bus based network has been developed by Volvo Penta for marine use with heavy duty connectors and cables. It is based on the same technology as is used in airplanes, ships and cars today.

The design has redundancy with twin independent circuits between wheelhouse and drive units, plus several safety functions in the system that minimize the risk of damage to engines or propulsion units. High speed impact is always a serious situation regardless of what drive system the boat has! Volvo Penta IPS has designed in a pre-set break point, all to reduce the risk of causing leakage.

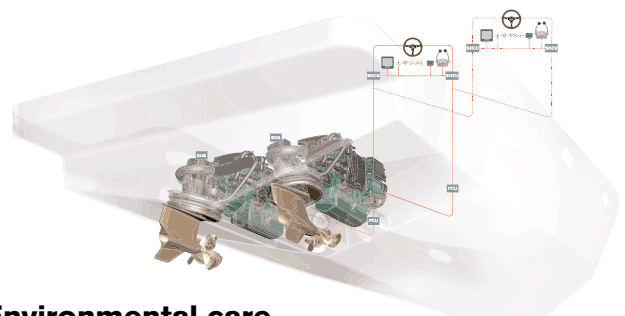

Environmental care

The Volvo Penta IPS has been developed as a complete integrated system with excellent environmental performance as one of the main design targets. The very high efficiency of the Volvo Penta IPS system gives greatly reduced overall emissions.

Volvo Penta's D13 engines have been developed from the latest design in modern diesel technology. The engines have a robust block with a strong ladder frame reinforcement and a one-piece cylinder head, forming the base for a smooth-running and durable engine. The new third generation high pressure electronic unit injector system, 4-valve technology, dual stage turbo connected to twin efficient charge air coolers all governed by the electronic engine management system result in efficient combustion with world-class diesel performance. This produces a unique acceleration capability while maintaining clean exhausts, low emissions and fuel consumption. The engines comply with IMO NOx limits and the comprehensive emission requirements EU IWW and US EPA Tier 2.

VOLVO PENTA IPS 1050

General Data

Volvo Penta IPS system designation.....	IPS1050
Engine displacement, l (in ³)	12.8 (780)
Configuration.....	in-line 6
Crankshaft power, kW (hp).....	588 (800) @ 2300 rpm
Propshaft power, kW (hp).....	556 (756) @ 2300 rpm
Aspiration	Dual stage turbo with twin charge air coolers
Rating.....	4
Package dry weight, approx. kg (lb).....	2300 (5060)
Propeller series.....	Q2-Q8
Voltage.....	24V
Application.....	Twin/multiple engine installation in planing hulls
Speed range.....	28 to 40 knots

Technical data according to ISO 8665. With fuel having an LHV of 42,700 kJ/kg and density of 840 g/liter at 15°C (60°F). Merchant fuel may differ from this specification which will influence engine power output and fuel consumption.

The engines comply with IMO NOx limits and the comprehensive emission requirements EU IWW and US EPA Tier 2.

Contact your local Volvo Penta dealer for further information.

Not all models, standard equipment and accessories are available in all countries. All specifications are subject to change without notice.

The engine illustrated may not be entirely identical to production standard engines.

Service

Diagnostics and fault tracing are easily performed by any authorized Volvo Penta service dealer. Repair work is much easier than with inboard shafts. The Volvo Penta IPS is developed, manufactured and serviced by one company with all parts from helm to propeller cone easily available off-the-shelf, reducing the down time.

With the propellers placed under the hull marine growth is minimized, and with all components exposed to seawater made of either nickel-aluminum-bronze or stainless steel, excellent corrosion resistance is achieved. The yearly service consists of conventional maintenance items, change of anode and a visual inspection. The oil and filter in the propulsion unit is replaced every second year or 400 hrs.

Other options

- **Color LCD display**
- **Trip computer**
- **Dynamic Positioning System**
Just the touch of a button activates the Dynamic Positioning System that holds your boat's position and heading even with wind and current action. Specially designed software works together with a twin receiver GPS antenna to operate and maneuver your IPS system automatically.
- **Power thrust mode**
Dedicated for forceful maneuvers.
- **Active Corrosion Protection (ACP) for Volvo Penta IPS**
3-level protection for your IPS system, integrated with EVC. Protects your investment from stray current damage and gives you peace of mind.

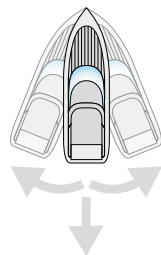
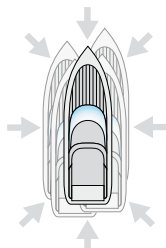

The Joystick Revolution



With the joystick the helmsman can now maneuver the vessel in any direction at low speed – with just one hand. The joystick is coupled to a sophisticated and specially developed software that individually commands the electronically engines and the pod units to steer, throttle and shift gears independently, making the boat move in any direction the driver wants – sideways, diagonally, forward, backward or rotate. Visit volvopenta.com to see for yourself!

Docking Station

You can have a joystick at a helm station, or “stand-alone” without controls and steering wheel. Place one on the aft deck or wherever you have best visibility! Up to four joysticks are possible.

VOLVO PENTA

AB Volvo Penta
SE-405 08 Göteborg, Sweden
www.volvopenta.com